

Dense plasma source development and jet injection in Globus-M*

Alexander V. Voronin,
Vasily K. Gusev,
Yury V. Petrov,
Evgeniy E. Mukhin,
Sergey Yu. Tolstyakov,
Gleb S. Kurskiev,
Michail M. Kochergin,
Kurt G. Hellblom

Abstract. Progress in the development of a plasma jet source and its utilization for injection of hydrogen plasma and neutral gas jets into the Globus-M spherical tokamak are presented. The latest version of the high kinetic energy gas and plasma jet source with titanium hydride grains is described. Reproducibility of the gas jet generation was increased due to automatic loading of fresh grains into the source before every shot. It allows producing stable gas release for many discharges. Impurity radiation intensity from the plasma jet was decreased by more than 100 times by preliminary processing titanium hydrate grains and developing a new filter. The result of special experiments on two colliding jets is discussed. It was confirmed that the plasma jet recombines into a gas jet after it escapes the source edge and has a kinetic energy higher than the hydrogen ionization potential. Hydrogen plasma jet with low impurity content has a density up to $2 \times 10^{22} \text{ m}^{-3}$, a total number of accelerated particles $(1-5) \times 10^{19}$ and a flow velocity of $\sim 200 \text{ km/s}$. It was used as an instrument for density control in Globus-M. Jet injection into deuterium plasma core during current plateau phase led to fast density increase in all spatial points of the plasma column including the plasma central region. Such injection allowed density doubling in the tokamak plasma. The model predictions are consistent with the experimental observations of the density raise recorded by the interferometer and Thomson scattering.

Key words: plasma gun • spherical tokamak • fuelling system

A. V. Voronin✉, V. K. Gusev, Yu. V. Petrov,
E. E. Mukhin, S. Yu. Tolstyakov, G. S. Kurskiev,
M. M. Kochergin, K. G. Hellblom
A. F. Ioffe Physico-Technical Institute,
26 Politechnicheskaya Str.,
194021 St. Petersburg, Russia,
Tel.: +7 812 292 71 21, Fax: +7 812 292 10 17,
E-mail: voronin.mhd@mail.ioffe.ru

Received: 14 January 2008
Accepted: 16 May 2008

Introduction

Interaction of dense plasma flows with magnetic fields and with high temperature magnetized plasma is one of the fundamental problems in fusion and space plasma research. The dense plasma flows may be created in laboratory conditions with a special kind of devices, dense magnetized plasma (DMP) sources. DMP sources may have application in nuclear fusion research with future utilization in fusion power reactors as possible efficient fuelling sources. Plasma accelerators, producing clean, high density, high speed plasma and gas jets could be used for this purpose. They are compact, non expensive and technologically simple compared with the devices currently used in fusion programme.

The injection of plasma and gas dense, high speed jets into a tokamak may result in fast density increase. Local enhancement of plasma density can be used for density profile control. Also such jets can influence the behaviour of MHD instabilities at the plasma edge (e.g.

* Presented on 3rd Research Coordination Meeting on Dense Magnetized Plasmas, 9–13 April 2007, Beijing, China.

Edge Localized Mode) and prevent plasma parameter degradation. Plasma start-up in a tokamak with the help of plasma jet was demonstrated and resulted in faster heating of the plasma column as compared to the conventional gas puffing method assisted by ECR preionization. Also intensive gas jet injection before the major plasma disruption can mitigate it and avoid uncontrollable energy release to the first wall.

One of the most attractive fusion relevant scenarios is a high plasma density regime as the fusion power depends squarely on the density [5]. The spherical tokamak Globus-M has a programme for the development of a method for density control as well as the achievement of ultimately high densities due to unique technical characteristics of the machine [4]. Experiments with injection of the dense high speed plasma jet into Globus-M have demonstrated the viability of such method of fuelling with minimum plasma perturbations [1, 14, 15].

Worldwide, different techniques for filling the plasma installations with particles, or fuelling during the work cycle are used. Among them are accelerators of solid matter, high pressure gas sources and plasma accelerators [6, 7, 9, 10]. In gas and plasma accelerators the injected fuel must have a high enough directed energy to pass through the magnetic field, dense and hot plasma border prior to reach the central plasma region of a reactor. The total number of accelerated particles has to be in the range of 10^{19} – 10^{23} for jet densities $> 10^{21} \text{ m}^{-3}$ and flow velocities of up to 800 km/s. In spite of definite demands for fuelling the plasma core region in a fusion reactor, no ideal method of fuel injection exist as yet. There are accelerators of condensed substances with relatively low velocity of pellet motion. And there are sources of low-density plasma with high velocity of the flow. But none of these plasma sources generates simultaneously the dense highly ionized and pure plasma with high directed velocity. Plasma accelerators, producing low impurity content, high density, high speed plasma and gas jets could be used for this purpose.

Earlier research carried out at the Ioffe Physico-Technical Institute has culminated in the development of a fuelling method and a pulsed accelerator producing an intense, dense hydrogen plasma jet. Development of double-stage plasma sources utilizing granules has been successfully tested [16]. The source has several attractive characteristics, such as: strong gas release and/or strong plasma release in 0.1 ms time, possibility of choosing different gases that can be absorbed in grains. The mock-up model with titanium-hydride grain sources was able to demonstrate plasma density exceeding 10^{22} m^{-3} and a total number of released particles of about 5×10^{19} , an efficiency of ionization of 90% and a velocity of flow motion up to 200 km/s. The hydrogen plasma jet contained low level of impurities which was confirmed by spectral and gas analyses.

Investigation, optimization and usage of the plasma jet source in Globus-M permitted to validate its efficiency as flexible tool for plasma fuelling and density profile control.

The present report is devoted to description of the progress in the plasma jet source development and to the discussion of plasma and gas jet injection experimental results obtained during experimental application

of the jet as a fuelling source of the Globus-M plasma with different parameters.

Development of the plasma source

We designed, constructed and investigated a novel double stage source that gave a dense and high directed velocity plasma. The operational principals are basically described in [16]. The source is being continuously developed to improve the kinetic energy of the DMP jet (Fig. 1). Gas production, ionization and plasma-acceleration are performed by intense electric discharges interacting with the condensed substance to produce a gas cloud and a DMP cluster in succession. The source consists basically of two stages. The first (gas generating) stage contains titanium grains loaded with hydrogen. An electric discharge passing through the grains releases high-pressure hydrogen. Neutral hydrogen passing through a specially designed grid fills the accelerator electrode gap to a high pressure in a few tens of microseconds. The second (plasma generating) stage is actually a system of coaxial electrodes. An electric discharge fired through the gas between the coaxial electrodes provides gas ionization and plasma acceleration in the classical “Marshall gun scenario” [8]. Both stages of the source are connected to low inductance capacitor power supplies. Care was taken to minimize inductance of the discharge circuit and maximize power input into the source. The plasma source was installed on a 2 m^3 test bench vacuum chamber beyond the vacuum shutter. It was equipped with a number of diagnostics and data acquisition system.

First experiments were conducted with fresh titanium hydride grains loaded before a series of 50 shots. An electric discharge passing through the whole package of the grains released a quantity of hydrogen decreasing with a shot number. Latest design development allowed us to load fresh grains before each shot (Fig. 1). It consists of two chambers for fresh and

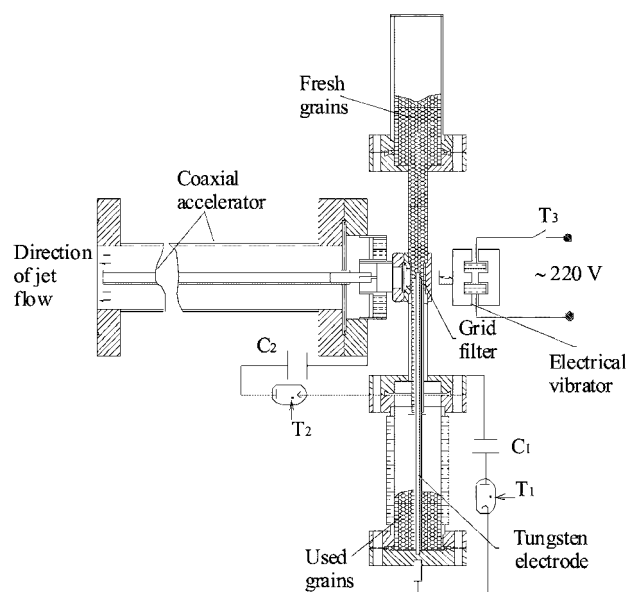

Fig. 1. Version of the source; fresh grains loaded before each shot.

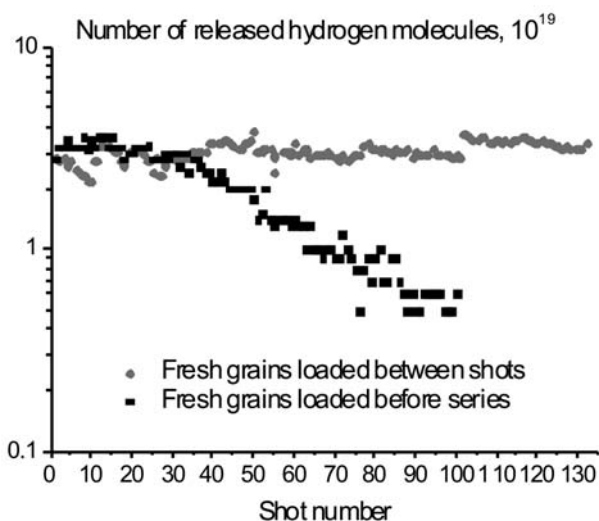

Fig. 2. Dependences of number of released hydrogen molecules on shot number.

used grains, and a thin channel between them where the electrical discharge releases the hydrogen. Because “fresh” grains were struck by the discharge each time a constant quantity of hydrogen was released by giving a stable gas release for many shots (Fig. 2).

Improvements of the jet source were made to reduce the pollution of the jet (Fig. 3). Before loading the titanium hydride grains into the source, they were cleaned with a compressed air inside of a volume surrounded by a thin grid. The size of the filter grid cell was reduced from 150 to 40 μm . These modifications considerably reduced impurities in the plasma jet. An AvaSpec 3648 spectrometer allowed us to analyse the radiation spectrum of the plasma jet. The impurity radiation was suppressed more than 100 times after cleaning the grains and gas cloud filtering.

Several successful modifications of the plasma gun were tested to get higher plasma jet parameters (velocity or density), namely:

- Gas generating and plasma accelerating stages were equipped with separate switches to increase the specific kinetic energy of the jet. Time delay between the switching was optimized which permitted increasing the plasma density (from 1×10^{22} to $2 \times 10^{22} \text{ m}^{-3}$).

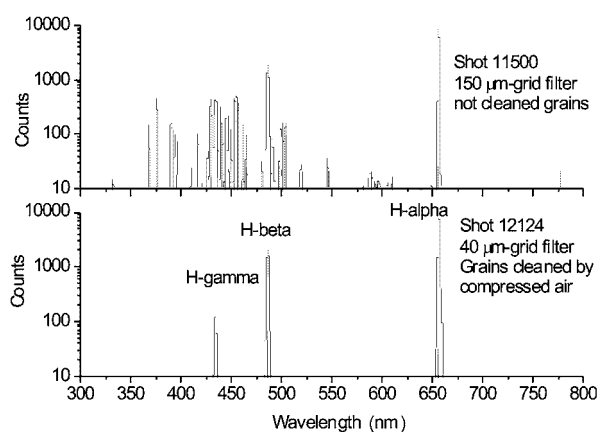

Fig. 3. Plasma jet spectra viewing along the source axis in the muzzle.

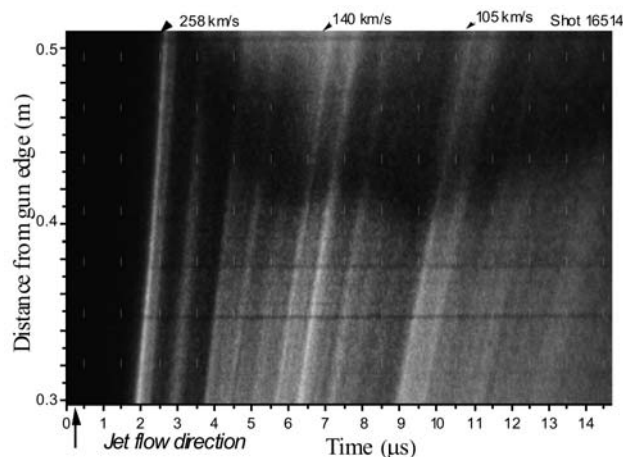

Fig. 4. Jet radiation observed through a narrow slit with a streak camera; shot 13898 – perpendicular view.

- To diminish some disregarded factors of minor design flaw we conducted an experiment with two accelerating stages. Double accelerating stage connected in series allowed increasing plasma flow velocity by $\sim 25\%$ in comparison with the acceleration by one stage.
- Additional efforts were made for reproducible initiation of the discharge in the second stage of the plasma source. The discharge, similar to the plasma focus technique, was initiated along the ceramic surface at the inlet of coaxial electrodes (muzzle) and accelerated along the whole muzzle length to the electrode outlet. Such development allowed us to increase plasma flow velocity from 100 up to 200 km/s at the same muzzle length ($\sim 0.35 \text{ m}$).
- Efforts were made to find alternative mechanisms for compact gas cloud release from the grains. The titanium hydride grains were irradiated by a Ruby laser. The laser an the output beam energy of 100 J and 1.2 ms duration was used. The titanium hydride grain layer was placed between stainless steel grid discs spaced at a few millimetres. This target was positioned in the gap of a coaxial accelerator. The laser beam irradiated grains and produced a gas cloud (number of particles $\sim 10^{19}$), which was ionized and accelerated. The produced plasma jet had characteristics similar to the jet created by the traditional (electrical) activation of the grains.

Experiments on time resolved plasma flow radiation were carried out. A streak camera registered time resolved radiation of the jet viewing through a thin slit (Fig. 4). Observations showed that the flow consists of discrete jets with their own values of velocity (from 100 to 260 km/s).

In another experiment, a CCD camera registered time integrated radiation of two colliding jets (Fig. 5). The distance between two oppositely directed plasma guns was 2 m. This experiment confirmed an earlier observation that the plasma jet recombines into a jet of neutrals at a distance of $\sim 0.8 \text{ m}$ from the source edge. Halfway between the sources, the jets collided and ionized again, as the jet of neutrals had a kinetic energy higher than hydrogen ionization potential.

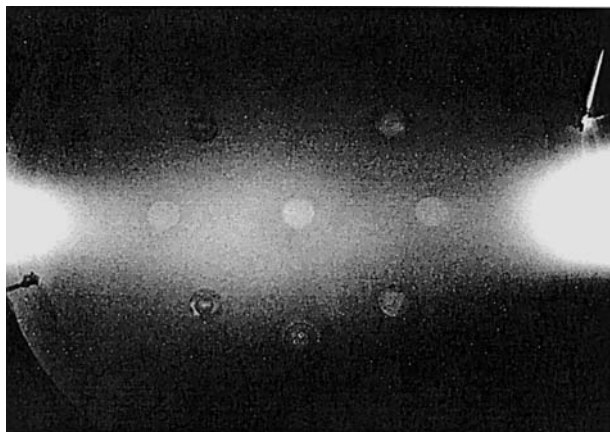

Fig. 5. Radiation of two colliding jets; the plasma jet recombines into the gas jet at a distance of ~ 0.8 m from the gun edge; near centre of the picture jets collided and ionized again.

Jet injection into the Globus-M tokamak

The design description, operational principles and experimental programme of the Globus-M tokamak are described in [5]. A general view of the tokamak is presented in Fig. 6. The experiments were performed in the following conditions: aspect ratio $A = R/a = 1.5$, major plasma radius $R = 0.36$ m, minor plasma radius $a = 0.24$ m, toroidal magnetic field at the vessel axis $B_T = 0.4$ T, plasma current $I_p = 0.2$ MA, average plasma density $n_e = (1 - 6) \times 10^{19} \text{ m}^{-3}$, pulse duration with inductive current drive $\tau_{\text{pulse}} \leq 0.1$ s. The plasma source was placed at the equatorial plane (Fig. 7). Two applications of plasma jet injection have been studied, the first being plasma discharge initiation. The jet was fired during the breakdown phase instead of using ECR preionization and vacuum vessel prefilling with working gas. The second application was the plasma density regulation. The hydrogen jet was injected into

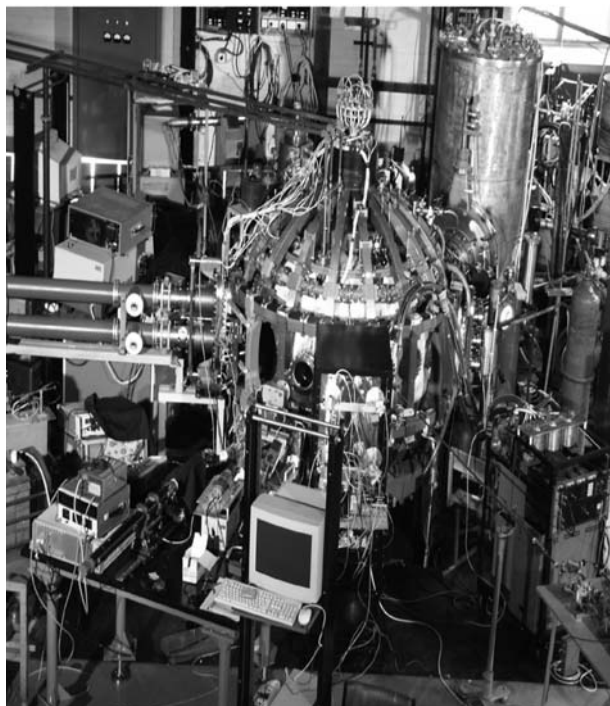

Fig. 6. General view of the Globus-M installation.

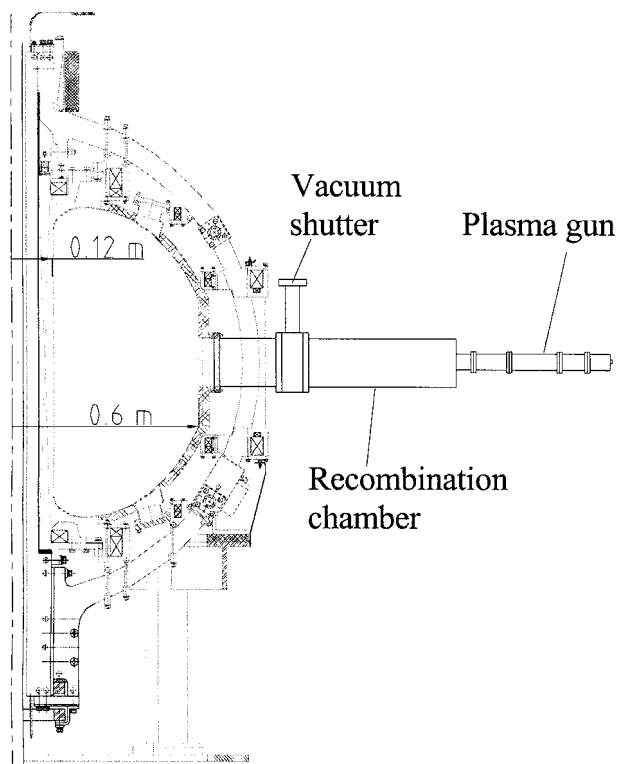

Fig. 7. Two stage plasma gun placed at the spherical tokamak Globus-M.

deuterium plasma during the current plateau. The experiments were aimed at detail investigations of the jet penetration into the plasma core. Parameters of the main plasma were measured during injection of the DMP jet into the tokamak.

Plasma start-up was made with a number of injected particles comparable with the total number of particles in the tokamak ($5 \times 10^{18} - 10^{19}$). The discharge was initiated by means of plasma jet injection into 0.4 T toroidal field. Experiments were performed in conditions both of single (at zero current in the central solenoid) and double (at the maximum current in the central solenoid) swing central solenoid operation regime. The injection of the plasma jet at zero current in the central solenoid created better conditions for breakdown and building up plasma current at lower MHD activity as compared with ECR preionization and neutral gas prefill. The plasma parameter traces in the discharge, initiated by means of the plasma jet are shown in Fig. 8 (left waveforms). One could see that the plasma current ramped up faster and to higher value at the same loop voltage waveform than with the traditional method. It is also seen that the magnetic turbulence during current ramp-up is lower in the case of injection. Plasma density reached a higher value; background radiation of H_α line was lower than with gas-puffing and preionization system. In operation regime with a maximum current in the central solenoid the maximum of the spectral line intensities (D-alpha and CIII) were shifted to the beginning of the discharge (Fig. 8 right waveforms). Higher plasma current and earlier excitation of spectral lines may confirm more intensive plasma heating at the initial stage of the discharge.

In earlier campaigns plasma injection during the current plateau phase was made with a plasma jet velocity

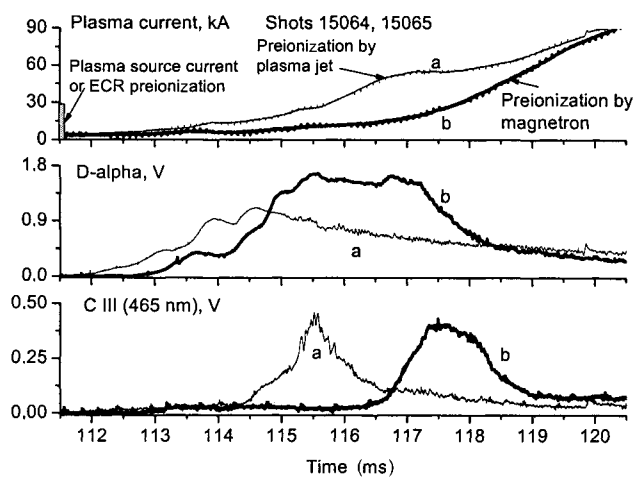
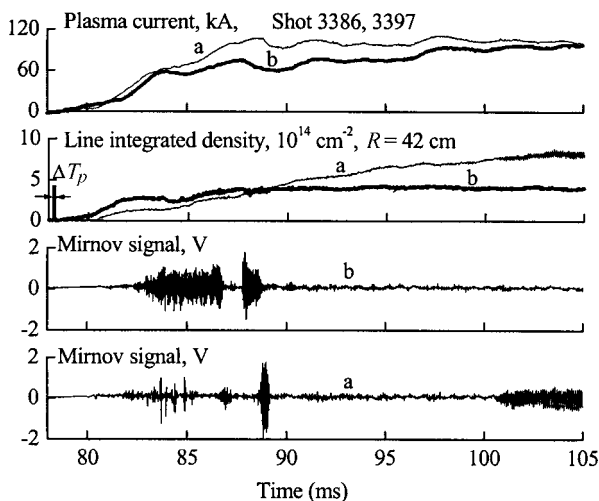

Fig. 8. Time dependences of some plasma parameters in Globus-M at different discharge initiation conditions: a – with plasma gun; b – with gas prefill and ECR preionization; shots 3386, 3397 – with single swing solenoid operation; shots 15064, 15065 – with double swing solenoid operation.

and density near the gun edge not exceeding 100 km/s and 10^{22} m^{-3} , accordingly [1, 14, 15]. The hydrogen jet was injected into Globus-M in OH deuterium plasma at a small angle (15 degrees) to the vertical axis from the low field side. The jet injection led to an increase of the plasma average density. The density increased during 1 ms following the gun shot. Injection of the plasma jet led to a faster increase of the plasma density compared with gas puffing (more than 15 ms).

In present experiments, the hydrogen jet was injected into Globus-M in OH deuterium plasma at the equatorial plane along the major radius from the low field side (Fig. 7). The jet speed was increased up to 200 km/s and density up to $2 \times 10^{22} \text{ m}^{-3}$ [2, 3, 12, 13]. Waveforms of plasma discharge parameters in Globus-M under such plasma jet injection are presented in Fig. 9. It is seen that it led to an essential enhancement ($< 0.5 \text{ ms}$) of the plasma average density and of the local plasma density in the core. The density increases at all radiuses of plasma column.

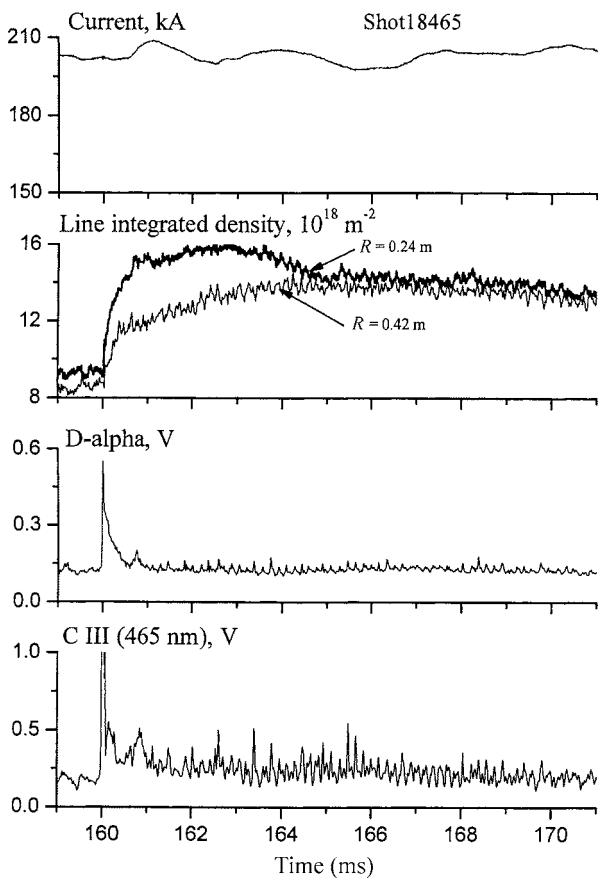

Fig. 9. Waveforms of plasma discharge parameters in Globus-M under improved plasma jet injection.

Evolution of the density profile in Globus-M during such jet injection measured by Thomson scattering is presented in Fig. 10. One can see a doubling of the plasma density in all spatial points of the tokamak in $\sim 2 \text{ ms}$.

The efficiency of jet penetration for different target plasma densities was investigated. The line integrated density enhancement along vertical horde at $R = 24 \text{ cm}$ in 1 ms after jet injection was measured with an interferometer. The dependence of the enhancement on the initial plasma density in Globus-M is presented

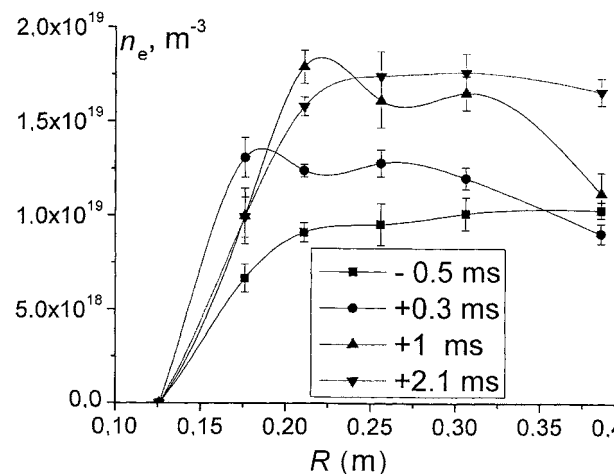

Fig. 10. Evolution of the density profile in Globus-M under jet injection. Thomson scattering data.

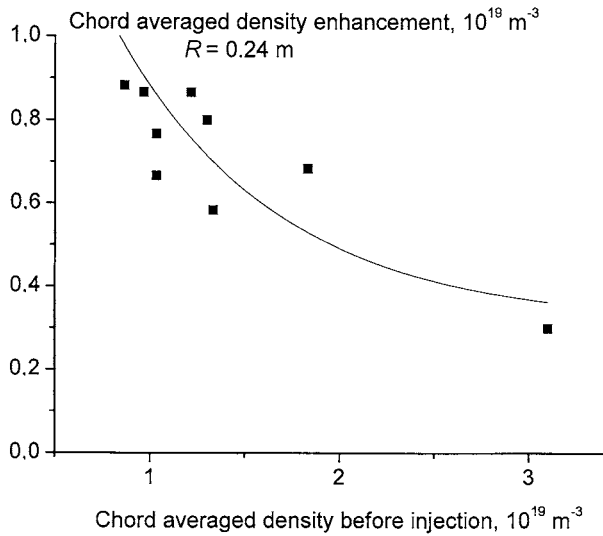

Fig. 11. Dependence of density enhancement in 1 ms after jet injection on initial plasma density in Globus-M.

in Fig. 11. It is seen that the density rise decreases with increasing initial plasma density in the tokamak. This experimental fact confirms that the increase of the initial density of the target plasma decreases the jet penetration efficiency. The model for jet penetration into the tokamak was applied for the high-velocity jets accelerated by the plasma gun on Globus-M [11]. The modelling showed that jet penetration into the plasma core strongly depends on the ratio between the jet and core densities (penetration depth is inversely proportional to the square root of ambient plasma density and proportional to the jet density). Therefore, for higher ambient plasma density the penetration depth would be lower. The model predictions are consistent with the experimental observations presented in Fig. 11.

Experiments were performed to clarify the influence of the length of recombination path on the jet penetration efficiency. Test bench experiments showed that the highly ionized plasma jet recombines during time of flight into a fast neutral flow. If the plasma jet does not recombine completely into neutrals, it may be deflected by the magnetic field to the walls. For comparison, the plasma jet was injected through 0.5 and 1.5 m recombination chambers. The source generated both a fast plasma and a slow tail of gas jet simultaneously. Waveforms of line integrated plasma density along different chords in Globus-M during plasma jet injection are presented in Fig. 12. The first (~ 1 ms) enhancement is a result of the fast fraction and the second (~ 4 ms) one of a slow fraction injected. One can see that the relative value of the fast fraction is higher at a 1.5 m recombination chamber, but both the fast and slow fractions are smaller in absolute value due to the jet divergence losses.

Discussion

The improved jet source with loading of fresh grains before each shot produced a stable and clean jet for many discharges. This source gave gas and plasma jets with specific kinetic energies in excess of those reached in an earlier study. The jet speed was increased up to

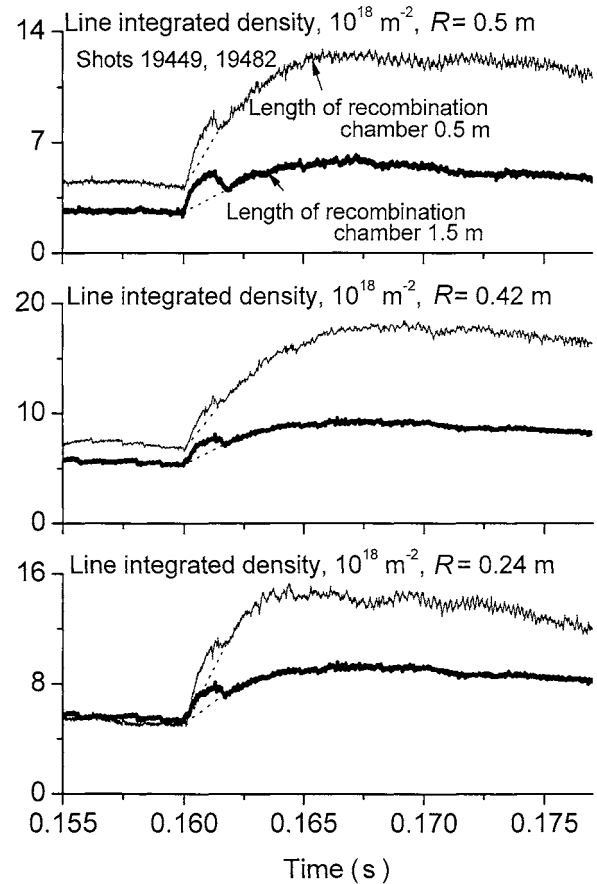

Fig. 12. Waveforms of line integrated density under jet injection through 0.5 and 1.5 m recombination chamber.

200 km/s and the jet density near the gun edge reached $2 \times 10^{22} \text{ m}^{-3}$. It is enough for fuelling a tokamak such as Globus-M. But further increasing the source parameters are required for large-scale tokamaks. Coaxial gun accelerates the plasma by $J \times B$ force. Raising the discharge current between coaxial electrodes can increase not only kinetic energy of the jet but also the impurities. An attempt should be made to search the possibility of increasing magnetic field at a limited discharge current.

The experiments on discharge initiation by means of plasma jet both in conditions of a single and double swing central solenoid operation regime showed that the current ramps up faster with the plasma gun initiation, than with traditional ECR preionization of filling gas. The higher plasma current and earlier excitation of spectral lines may confirm more intensive plasma heating at the initial stage of the discharge. This method could be used for efficient ignition of the discharges in fusion reactors.

Deep jet penetration into toroidal magnetic field of Globus-M was observed and a doubling of the density was achieved. Now, it is clear that the effect of density increase partly can be attributed to the stream of neutrals penetrating into the tokamak after plasma jet recombination during time-of-flight outside the tokamak vessel boundary. This is additionally confirmed by the test bench experiments with two colliding jets.

The magnetic field penetration is obligatory, but not sufficient condition for deep plasma fuelling. The experiments with a significantly decreased magnetic

field did not show any deeper jet penetration into the tokamak plasma. That means that the ratio of specific kinetic energy of the jet to magnetic field pressure does not play any exceptional role in the interaction between the plasma jet and the tokamak plasma confined by the magnetic field. Plasma pressure (temperature or density) could be an additional factor that reduces the jet penetration. It has been established experimentally that the increase of the initial density of the target ohmic heating plasma decreased the jet penetration efficiency. Modelling showed [11] that both the neutral jet and plasma jet penetration into the plasma core strongly depend on the jet velocity and ratio between the jet and core densities. Therefore, for higher jet velocity and density, and lower ambient plasma density the penetration depth would be higher. Important result of the simulations is the weak sensibility of particle deposition to the initial ionization degree of the jet. It was found that the initially neutral jet is getting ionized within $0.5 \mu\text{s}$, i.e. penetrates up to 5 cm assuming constant velocity, so that the ionization time is smaller than any other characterizing time in the problem. At the current stage of the research, we can say about equal contribution of the plasma jet and neutral jet components into the density raise effect recorded during injection experiments. But neutral jet is preferable because it penetrates more efficiently into the confining magnetic field surrounding the plasma core.

Conclusions

Investigations confirmed that the developed DMP source has a potential in nuclear fusion energy research and in fusion applications. The novel type of clean plasma source for DMP production and acceleration was investigated in plasma fuelling experiments. Several modifications of the plasma gun were tested to get higher plasma jet parameters (velocity or density). An optimized source generated during $\leq 50 \mu\text{s}$ a clean, highly ionized hydrogen plasma with a density of $2 \times 10^{22} \text{ m}^{-3}$; total number of the accelerated particles $(1-5) \times 10^{19}$ and flow velocity 30–200 km/s. The latest design allows loading of fresh grains before each shot and the generation of stable gas release for many shots. The impurity radiation was suppressed more than 100 times after cleaning the grains and gas cloud filtering. The flow consists of discrete jets with their own value of the velocity. The highly ionized plasma jet recombines during time of flight into a fast neutral flow that can penetrate through magnetic fields. The jet of neutrals has kinetic energy higher than hydrogen ionization potential.

Plasma start-up in the tokamak with the help of the plasma gun showed better performance. The injection of plasma before the discharge created better conditions for breakdown and building up the plasma current at lower MHD activity as compared with ECR preionization and neutral gas prefill.

The experiments showed efficient jet penetration into the plasma core of Globus-M during the current plateau phase. They have confirmed the dependence of the jet penetration efficiency on the ratio between the jet and core densities, predicted by modelling.

Acknowledgment. The authors wish to thank IAEA Staff, the scientific, technical and engineering staff of the MHD Phenomena and Hot Temperature Plasma Physics Laboratories and to thank personally Dr R. G. Levin for his help in equilibrium data processing, Dr I. P. Scherbakov and Dr N. V. Sakharov for assistance with experiments, valuable comments and discussion. The authors wish to thank for grant support IAEA, Research Contract no. 12408 and RFBR 06-02-16709-a, 06-02-08186-ofi.

References

1. Abramova KB, Voronin AV, Gusev VK *et al.* (2005) Injection of high-density plasma into the Globus-M spherical tokamak. *Plasma Phys Reports* 31:721–729
2. Gusev VK, Ayushin BB, Chernyshev FV *et al.* (2006) Overview of the Globus-M spherical tokamak results. In: Proc of the 21st IAEA FEC, 16–21 October 2006, Chengdu, China, OV/P3
3. Gusev VK, Ayushin BB, Chernyshev FV (2007) First results on H-mode generation in the Globus-M spherical tokamak. In: Proc of the 34th EPS Conf on Plasma Physics, July 2–6, 2007, Warsaw, Poland, P1-078
4. Gusev VK, Burtseva TA, Dech AV *et al.* (2001) Plasma formation and first OH experiments in the Globus-M tokamak. *Nucl Fusion* 41:919–925
5. Gusev VK, Chernyshev FV, Golant VE *et al.* (2006) Density limits and control in the Globus-M spherical tokamak. *Nucl Fusion* 46:S584–S590
6. ITER Physics Expert Group on Divertor, ITER Physics Expert Group on Divertor Modelling and Database and ITER Physics Basis Editors (1999) Chapter 4: Power and particle control. *Nucl Fusion* 39:2391–2469
7. ITER Physics Expert Group on Energetic Particles, Heating and Current Drive and ITER Physics Basis Editors (1999) Chapter 5: Physics of energetic ions. *Nucl Fusion* 39:2471–2495
8. Marshall J (1960) Performance of a hydromagnetic plasma gun. *Phys Fluids* 3:134–135
9. Milora SL, Houlberg WA, Lengyel LL, Mertens V (1995) Pellet fuelling. *Nucl Fusion* 35:657–754
10. Raman R, Martin F, Haddad E *et al.* (1997) Experimental demonstration of tokamak fuelling by compact toroid injection. *Nucl Fusion* 37:967–972
11. Rozhansky VA, Senichenkov I, Veselova I *et al.* (2006) Penetration of supersonic gas jets into a tokamak. *Nucl Fusion* 46:367–382
12. Voronin AV, Abramova KB, Gusev VK *et al.* (2006) High kinetic energy jet injection into Globus-M spherical tokamak. In: Proc of the 21st IAEA FEC, 16–21 October 2006, Chengdu, China, EX/P3-18
13. Voronin AV, Abramova KB, Gusev VK *et al.* (2007) Generation and injection of intensive gas and plasma jets into the Globus-M tokamak. In: Proc of the 34th EPS Conf on Plasma Physics, July 2–6 2007, Warsaw, Poland, P4-161
14. Voronin AV, Gusev VK, Petrov YuV *et al.* (2005) High kinetic energy plasma jet generation and its injection into the Globus-M spherical tokamak. *Nucl Fusion* 45:1039–1045
15. Voronin AV, Gusev VK, Petrov YuV *et al.* (2006) High kinetic energy dense plasma jet. *Nukleonika* 51;1:85–92
16. Voronin AV, Hellblom KG (2001) Generation of dense plasma clusters with high velocity. *Plasma Phys Controlled Fusion* 43:1583–1592